



S9301-32D

400G Data Center Spine
Switch

Hardware Installation Guide

R1.4





Table of Contents

1	Overview	1
2	Preparation	2
2.1	Installation Tools	2
2.2	Installation Environment Requirements	3
2.3	Preparation Check List.....	4
3	Package Contents	5
3.1	Accessory List	5
3.2	Component Physical Information.....	6
4	Identifying Your System	7
4.1	S9301-32D System Overview	7
4.2	DC Version PSU Overview	8
4.3	AC Version PSU Overview.....	9
4.4	Fan Overview	10
4.5	Port Overview	10
5	Installing Fan Modules	15
6	Installing Power Supply Units	16
7	Grounding the Router	18
8	Connecting Power	20
8.1	DC Version	20
8.2	AC version.....	23
9	Verifying System Operation	24
9.1	Front Panel LED	24
9.2	PSU FRU LED	25
9.3	Fan FRU LED.....	25
9.4	Management Port LED	25
10	Initial System Setup	26
11	Cable Connections	27
11.1	Connecting the USB Cable.....	27
11.2	Connecting the OOB Management Cables.....	27
11.3	Connecting the Management Cables.....	28

11.4	Connecting the Transceivers	28
12	Cautions and Regulatory Compliance Statements	29



1 Overview

The UfiSpace S9301-32D is a high-performance, versatile open networking white box switch that is designed to address the fast-growing segment of the Ethernet switching market and the needs to push capacity to the next level.

With 32 x 400GE QSFP-DD ports, the S9301-32D switch is where computer resources (servers or blade chassis) are centralized and managed in a structured way utilizing high-efficiency Ethernet connectivity.

With advanced capabilities, these switches deliver performance and intelligence to the network edge in a flexible 1RU form factor that helps reduce infrastructure and administrative costs.

The S9301-32D is the epitome of future networking with a powerful 8-core processor and 32 high-speed 400GE interfaces. It comes with redundant, hot swappable components for convenience, increased availability, reliability and lower costs of maintenance.

This document describes the hardware installation process for S9301-32D.



2 Preparation

2.1 Installation Tools



Screwdriver (Phillips head #2)

Phillips #2 Screwdriver

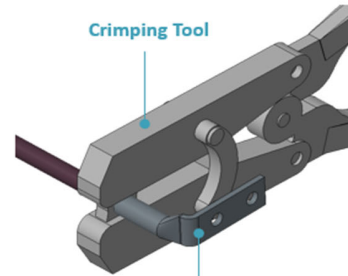

Crimping Tool

Grounding Lug

Crimping tool

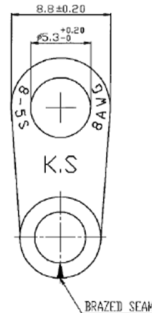

8 AWG wire with ring terminal for DC power supply

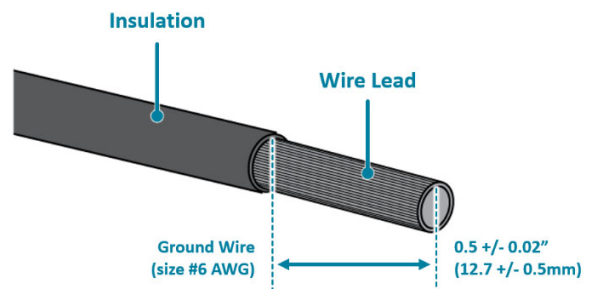

6-AWG wire for grounding



Wire-stripping tools for stripping 6-AWG copper wire

- PC with terminal emulation software. Refer to the "Initial System Setup" section for details.
 - Baud rate: 115200 bps
 - Data bits: 8
 - Parity: None
 - Stop bits: 1
 - Flow control: None

2.2 Installation Environment Requirements

- Power Reserve: The S9301-32D power supply is available with:
 1. **DC Version:** 1+1 active-active -40 to -75V DC power supply field replaceable unit or;
 2. **AC Version:** 1+1 active-active 200 to 240V AC power supply field replaceable unit.

To ensure the active-active feed power design functions properly, a field with dual power circuit is recommend with a reserve of at least 1300 watts on each power circuit.

- Space Clearance: The S9301-32D width is 17.17 inches (43.6cm) and shipped with a rack mount brackets suitable for 19 inch (48.3cm) wide racks. The depth of the S9301-32D chassis is 25.4 inches (64.5cm) without the field replaceable units (FRUs) and comes with adjustable mounting rails suitable for rack depths of 20 inches (50.8cm) to 35 inches (88.9cm). The handle for the fan units will extend outwards by 1 inch (2.5cm) and the handle for the power supplies will extend outwards by 1.5 inches (3.8cm). Therefore, to accommodate the fan and power supply handles, a minimum space clearance of 6 inches (15.24cm) is needed at the back of the S9301-32D. A total minimum reserve depth of 31.4 inches (79.7cm) is required.

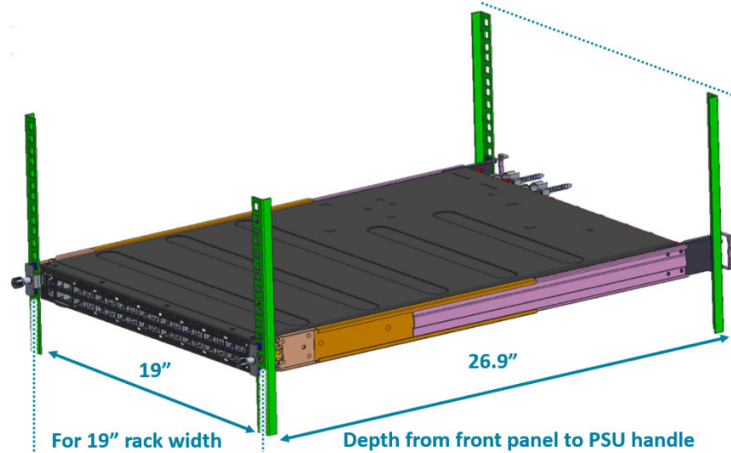

Figure 1.

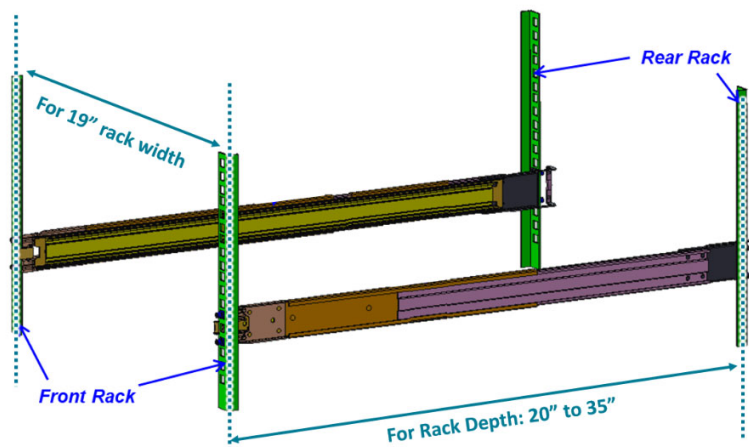



Figure 2.

- Cooling: The S9301-32D has two options for airflow direction. There is a back-to-front option (Figure 3. Left) and a front-to-back option (Figure 3. Right). Make sure the equipment on the same rack have the same airflow direction.

 Note	Ensure all installed fans and power supply units (PSUs) have matching airflow directions (indicated by the same handle color) to maintain proper system operation.
---	--

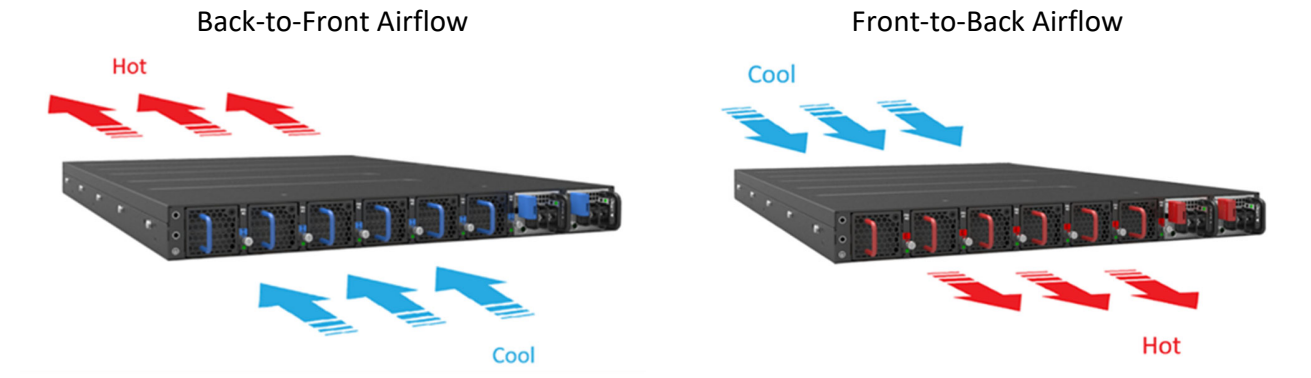

Figure 3.

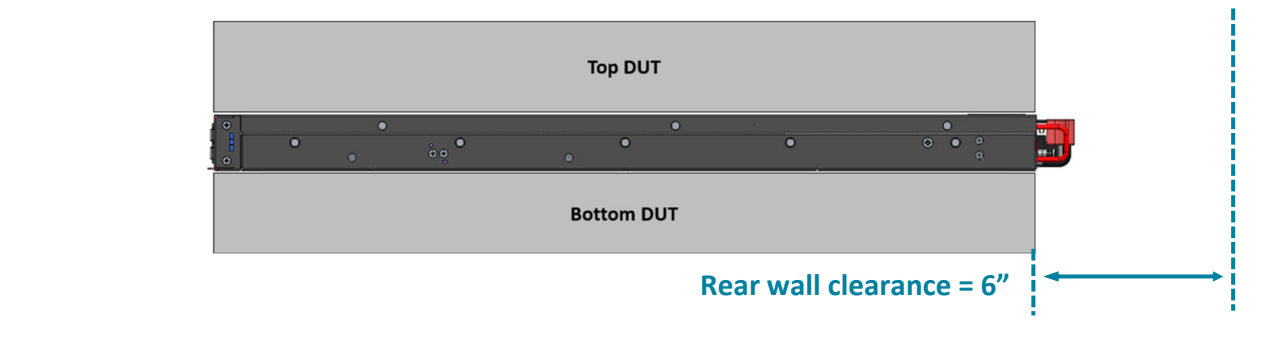

Figure 4.

2.3 Preparation Check List

Task	Check	Date
Power voltage and electric current requirement DC version: -40 to -75V DC, 40Ax2 maximum or; AC version: 200 to 240V, 7.5A x2 maximum		
Installation spacing requirement: S9301-32D is 1RU (1.75"/4.5cm) in height, 19" (48.3cm) in width, and 31.4 inches (79.7cm) in depth without considering cable routing		
Thermal requirement S9301-32D working temperature is 0 to 40°C (32°F to 104°F), airflow direction is front-to-back or back-to-front		
Installation tools required #2 Phillips Screwdriver, 6-AWG wire stripper, and crimping tool		

**Accessories required**

PC with terminal emulation software

3 Package Contents

3.1 Accessory List

Item	Description	Specs. & Dimensions	Qty.	Weight
1	Grounding Kit	1 x Grounding Lug (#6 AWG) 1.14" x 1.47" x 0.49" (29 x 37.5 x 12.5mm) 2 x Screw: M4*L8.0mm 2 x M4 Lock Washers	1 set	0.03lbs (15.3g)/set
2	DC Input Lug (DC version only)	4 x DC Input Lugs (#8AWG) 0.35" x 0.77" x 0.49 " (8.8 x 19.5 x 12.5mm)	1 set	0.03lbs (13.2g)/set
3	AC Power Cord (AC version only)	6' (1830mm)	2 pcs	0.77lbs (350g)/pcs
4	Adjustable Mounting Rail (for 4 posts)	2 x Mounting Rail 24.49" x 1.7" x 0.9" (20" to 35" rack depth) (622 x 44 x 22mm)	2 set	3.40lbs (1.54kg)/set
5	Screw Kit (for Adjustable Mounting Rail)	2 x Screws M4.0*L5.5mm	1 set	0.004lbs (1.9g)/set
6	RJ45 to DB9 Female Cable	8" (2438mm)	1 pcs	0.23lbs (105g)/pcs
7	USB 3.0 Cable	7.8" (200mm)	1 set	0.03lbs (13.6g)/set

3.2 Component Physical Information

Specification	Item	Description
Weight	Total package contents	54.45lbs (24.74kg)
	Chassis without FRU	25.0lbs (11.34kg)
	Power Supply Unit (PSU)	DC PSU: 1.94lbs (0.88kg) AC PSU: 2.22lbs (1.01kg)
	Fan module	0.41lbs (185g)
	Grounding lug kit	0.03lbs (15.3g)
	Adjustable mounting rail	3.40lbs (1.54kg)
	USB 3.0 cable	0.03lbs (13.6g)
	AC power cord (AC version only)	0.77lbs (350g)
	RJ45 to DB9 female cable	0.23lbs (105g)
Dimension	S9301-32D (W x D x H)	17.17" x 25.4" x 1.72" (436 x 645 x 43.8mm)
	PSU (W x D x H)	1.99" x 12.64" x 1.57" (50.5 x 321 x 40mm)
	Fan module(W x D x H)	1.71" x 3.93" x 1.57" (43.4 x 100 x 40mm)



4 Identifying Your System

4.1 S9301-32D System Overview

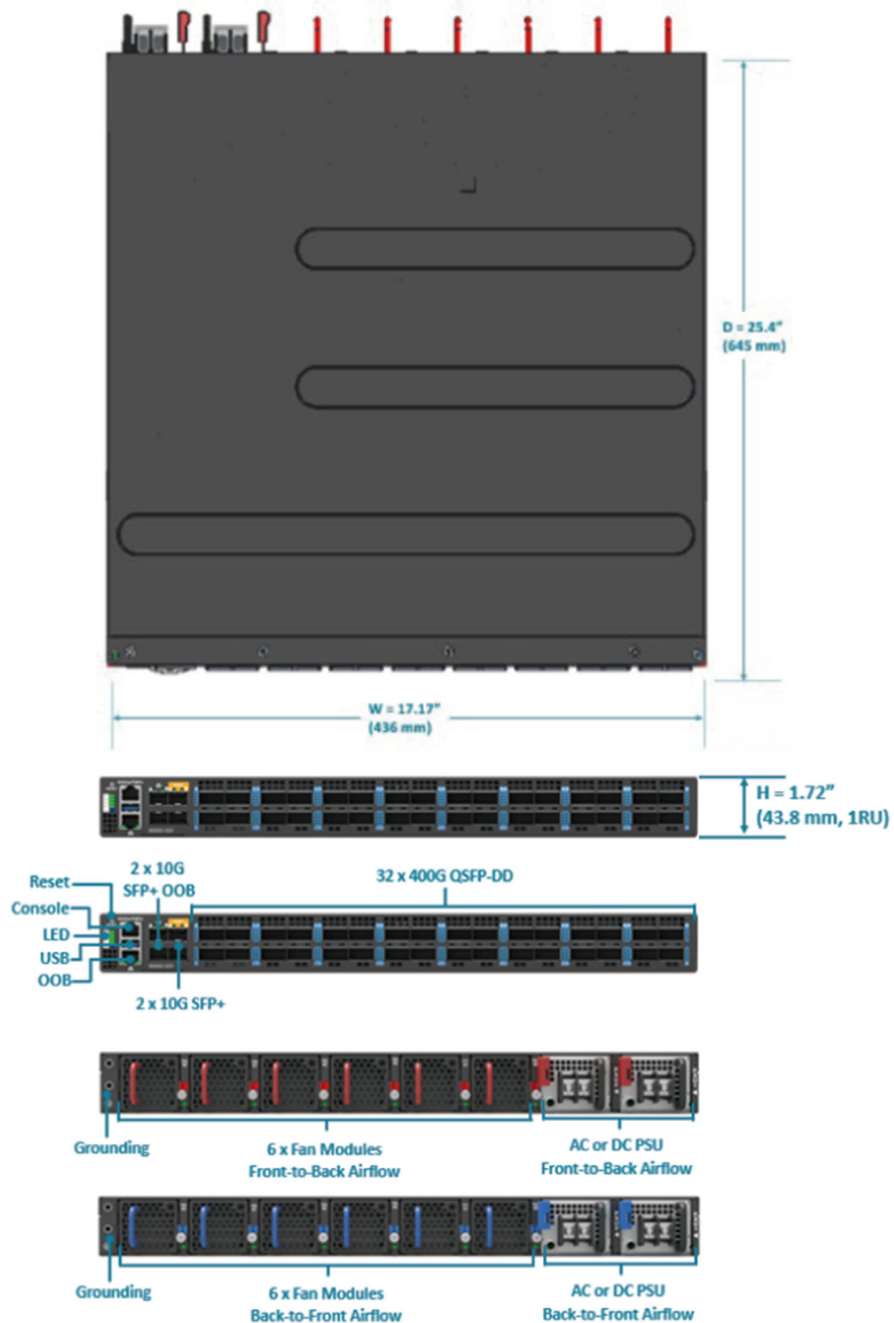

Figure 5.

4.2 DC Version PSU Overview

1+1, hot swappable power supply unit (PSU) field replaceable unit (FRU). There are two types of DC PSUs. The picture on the left is the DC PSU with back-to-front airflow, identified with a blue latch. The picture on the right is the DC PSU for front-to-back airflow, identified with a red latch.

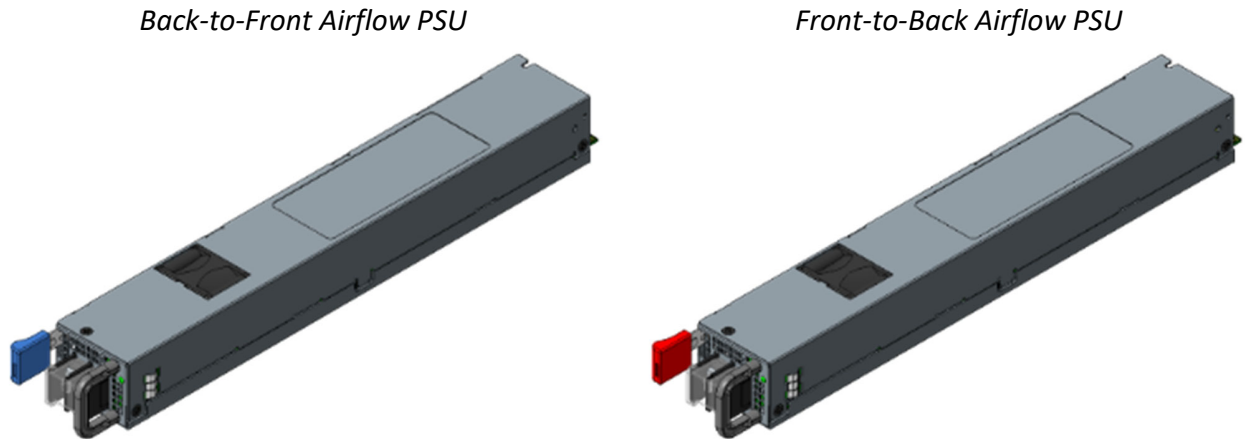
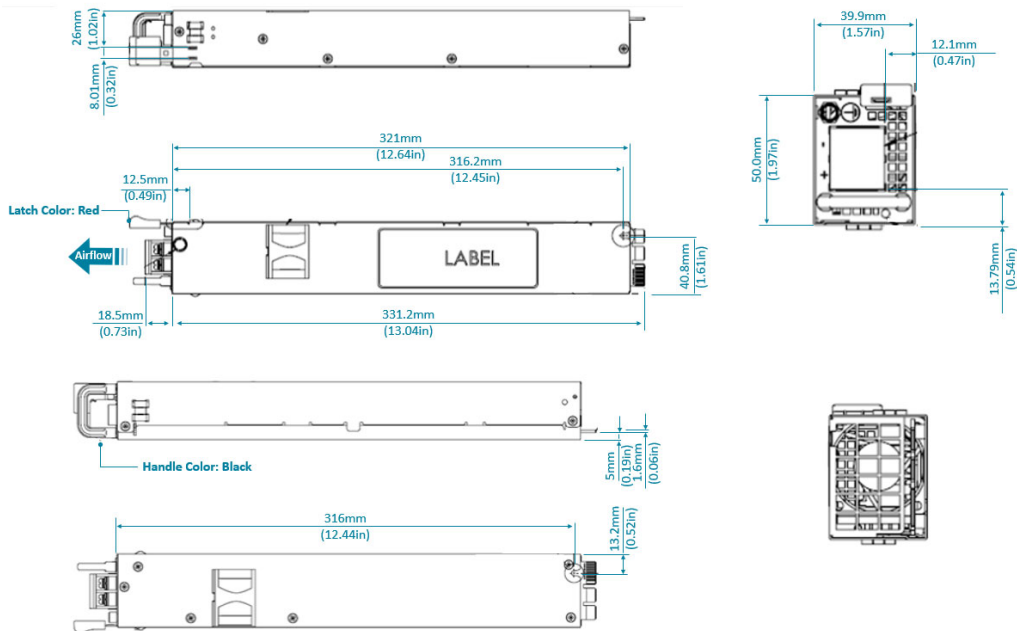

Figure 6.

The DC power supply units are the same size for both back-to-front airflow and front-to-back airflow. Therefore, only the dimensions for front-to-back airflow PSU will be provided in the figure below.



(Front-to-Back Airflow PSU)

Figure 7.

4.3 AC Version PSU Overview

1+1, hot swappable power supply unit (PSU) field replaceable unit (FRU). There are two types of AC PSUs. The picture on the left is the AC PSU with back-to-front airflow, identified with a blue latch. The picture on the right is the AC PSU for front-to-back airflow, identified with a red latch.

Back-to-Front Airflow PSU

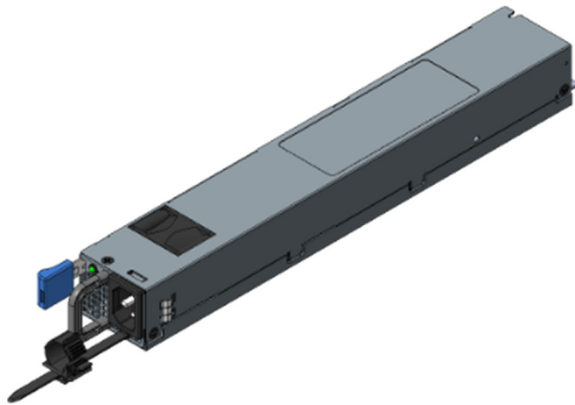

Front-to-Back Airflow PSU

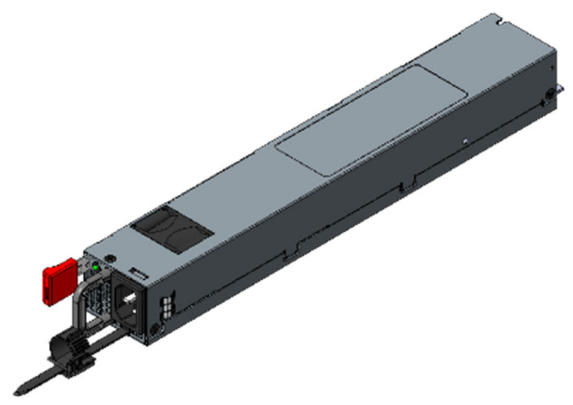
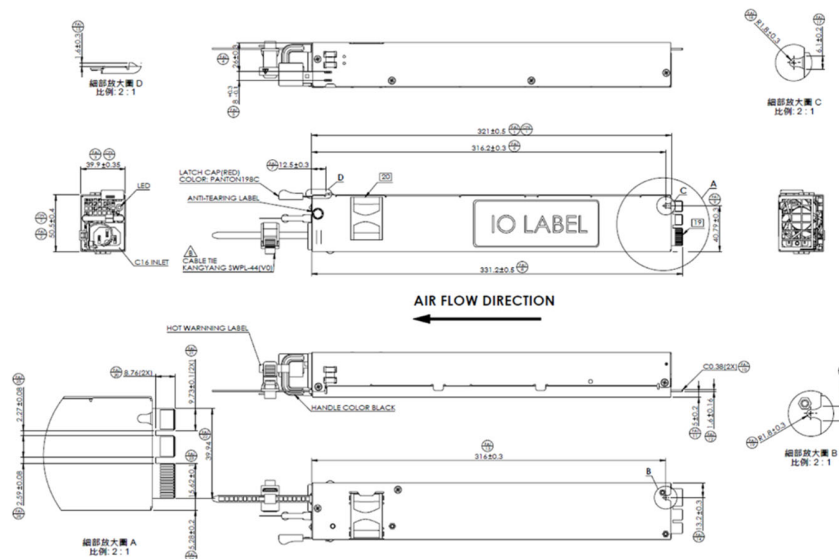

Figure 8.

The AC power supply units are the same size for both back-to-front airflow and front-to-back airflow. Therefore, only the dimensions for front-to-back airflow PSU will be provided in the figure below.



(Front-to-Back Airflow PSU)

Figure 9.

4.4 Fan Overview

5+1, hot swappable fan field replaceable unit (FRU). There are two types of fans, shown in the figure below. The top picture is for fans with back-to-front airflow, identified with a blue handle. The picture on the bottom is for the fans with front-to-back airflow, identified with a red handle.

	Note	Ensure all installed fans and power supply units (PSUs) have matching airflow directions (indicated by the same handle color) to maintain proper system operation.
---	-------------	--



(Back-to-Front Airflow Fans)



(Front-to-Back Airflow Fans)

Figure 10.

4.5 Port Overview

Port ID	Form Factor	Maximum Support Distance	Support Speed
0 ~ 31	QSFP-DD	49.7mi (80km)	400G
0~1	SFP+	6.21mi (10km)	1/10G

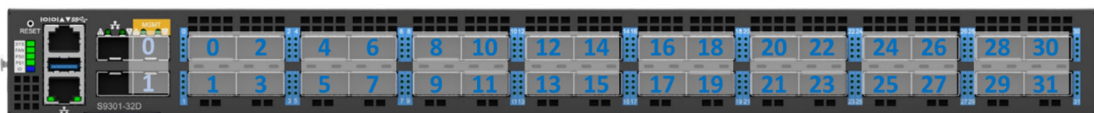

Figure 11.



The 400G QSFP-DD ports highlighted in brown support both ZR and OpenZR+ transceivers.

In a front-to-back or back-to-front airflow setup, you can install up to 8 ZR transceivers. (See the figure below for the port configuration)



Figure 12.

In a front-to-back or back-to-front airflow setup, you can mix and match ZR and OpenZR+ transceivers. Please noted if any OpenZR+ transceiver is used, you can only install up to 6 ZR/OpenZR+ transceivers to the S9301-32D. (See the figure below for the port configuration)



Figure 13.



Note

To prevent potential overheating, do not place ZR/OpenZR+ modules in adjacent ports.



Caution

It is recommended that installation be done by two trained professionals. One individual should hold the equipment in position on the rack while the other secures it in place.

1. Separate the adjustable rail slides.
 - 1.1 Pull apart the inner and outer rails until it is locked in place. An audible click can be heard when the rails are locked in place.
 - 1.2 Pull the white tab forward to unlock the rails in order to completely separate the inner rail from the outer rail. The white tab is located on the inner rail.
 - 1.3 Once the inner rail is separated, push the tab located on the outer rail to unlock and slide the middle rail back.

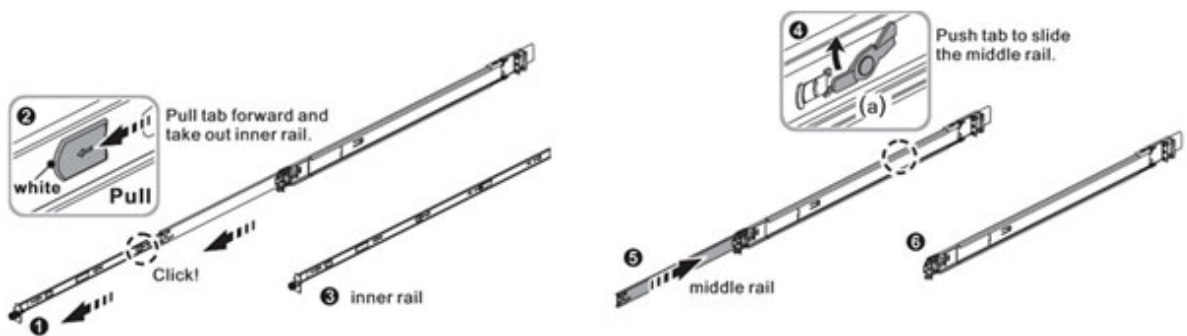

Figure 14.

2. Install the inner rails onto the chassis.
 - 2.1 The inner rail has key-shaped holes where attachment pins on the chassis can be aligned. The chassis has 5 attachment pins on each side, for a total of 10 pins. Fit the key-shaped holes with the attachment pins and pull back to hold the inner rack in place.



Note

Make sure the captive screw of the inner rail is positioned at the front of the chassis.

- 2.2 After the attachment pins are secured to the inner rail, lock the inner rail to the chassis using two M4 screws (one on each chassis side). See the figure below.

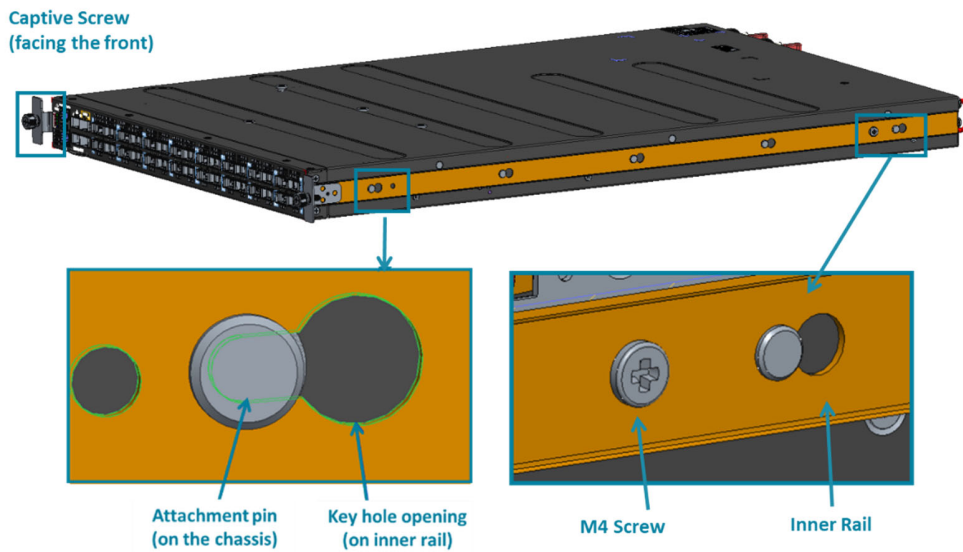

Figure 15.

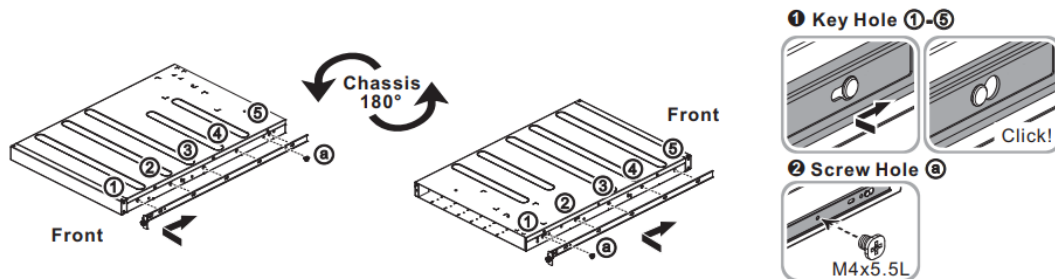
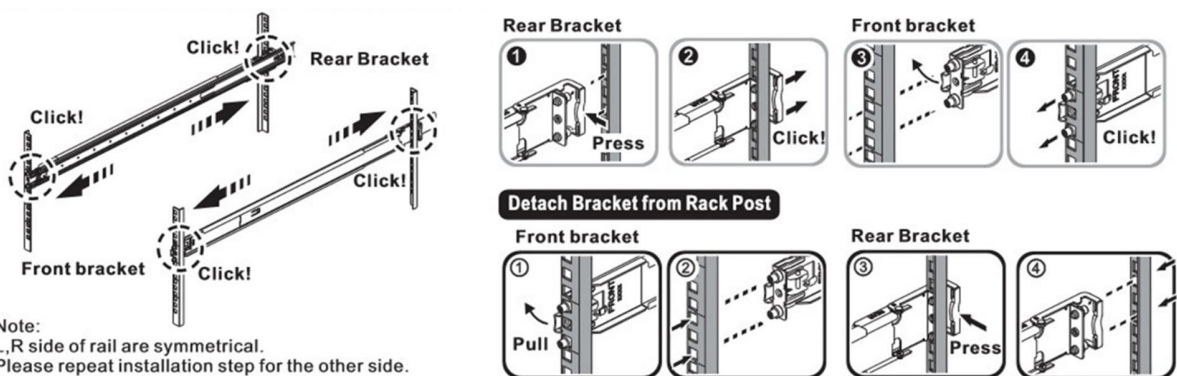

Figure 17.

3 Fix the outer rails onto the rack.

3.1 The outer rails have two brackets on the front and rear. Pull back the clip of the rear bracket to attach it onto the rack. An audible click can be heard when the bracket is secured onto the rack.

3.2 Once the rear bracket is secured, pull back the clip of the front bracket attach it to the rack. An audible click can be heard when the bracket is secured onto the rack.



Note:
L,R side of rail are symmetrical.
Please repeat installation step for the other side.

Figure 18.

- 4 Insert the Chassis to complete the installation.
 - 4.1 Pull the middle rail fully extended into lock position, an audible click can be heard when the middle rail is fully extended and locked into position.
 - 4.2 Insert the chassis by lining up the inner rails into the slot of the middle rail.
 - 4.3 Slide the chassis into the middle rail until it hits a stop.
 - 4.4 Push the blue release tab on each rail to unlock the rails and slide the chassis all the way into the rack.
 - 4.5 Lock the chassis into place by using the captive screw on the front of the inner rail.

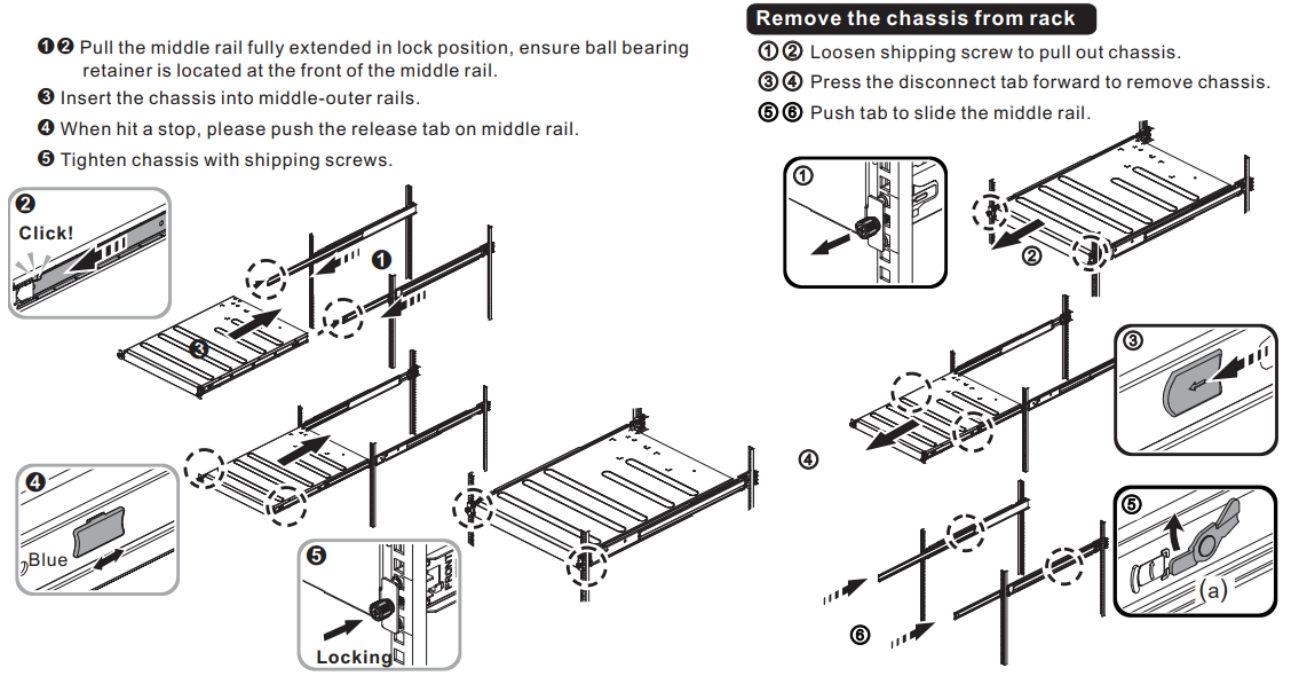

Figure 19.



5 Installing Fan Modules

The fan modules are hot swappable field replaceable units (FRUs), which can be replaced while the router is operating as long as all the remaining modules are installed and in operation. The fans come pre-installed and the following steps are instructions on how to install a new fan module.

1. Loosen the captive screw located on the fan module.

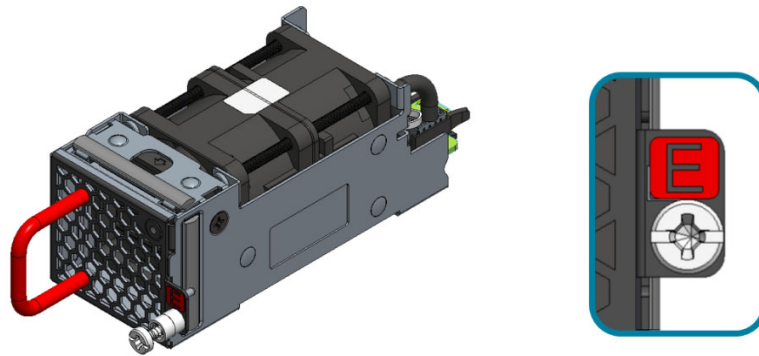

Figure 20.

2. Grip the fan's handle and firmly pull it out of the fan bay.

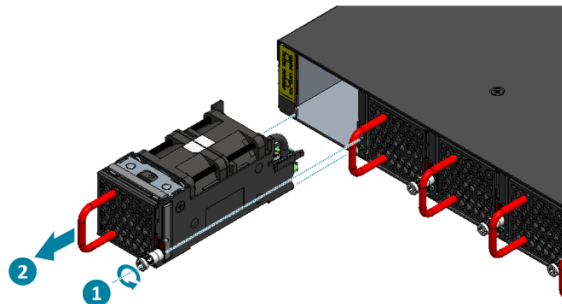

Figure 21.

3. Align the new fan module with the fan bay.
4. Carefully slide the new fan module into the fan bay and gently push until it is flush with the case.
5. Secure the captive screw on the fan module to lock the fan in place.

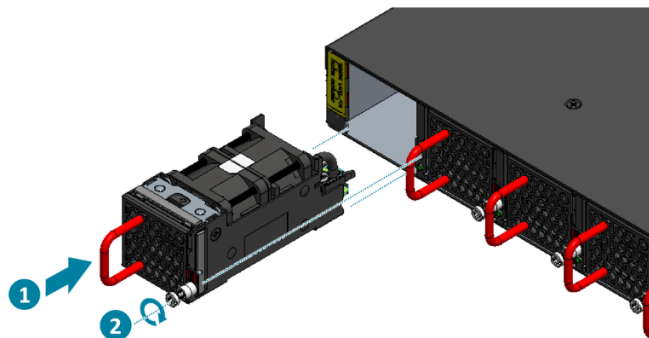

Figure 22.



6 Installing Power Supply Units

The power supply unit (PSU) is a hot swappable field replaceable unit (FRU) and can be replaced while the router is operating as long as the remaining (second) PSU is installed and in operation. The PSUs comes pre-installed and the following are instructions on how to install a new PSU. The process for removing and installing the PSUs are the same for all models.



If power input for AC power supply is only 110V, there will only be 1000 watts per power supply and will not be enough power for the power supply to be changed while the router is in operation. In order for AC power supply to be changed while the router is in operation, ensure that 220V power is supplied.

DC:

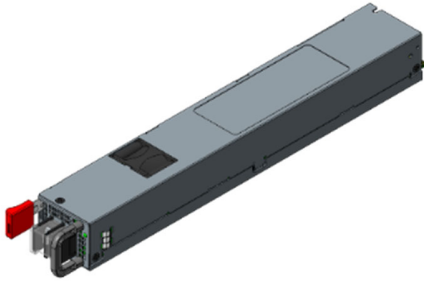

AC:

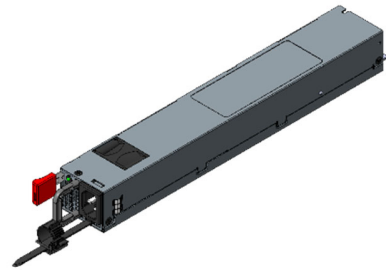

Figure 23.



Shock hazard!
For safety, please disconnect all power inputs from the power supply unit before servicing the router.

1. Locate the release tab on the PSU. Then press and hold down the release tab to unlock the PSU from the power bay.
2. While holding down the release tab, grip the PSU's handle and firmly pull it out of the power bay.

DC Version:

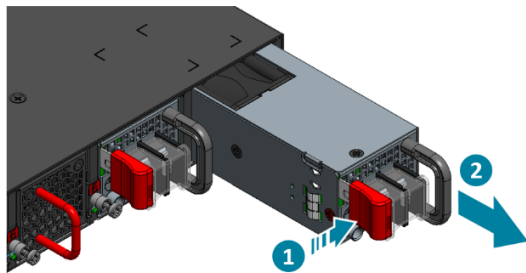

AC Version:

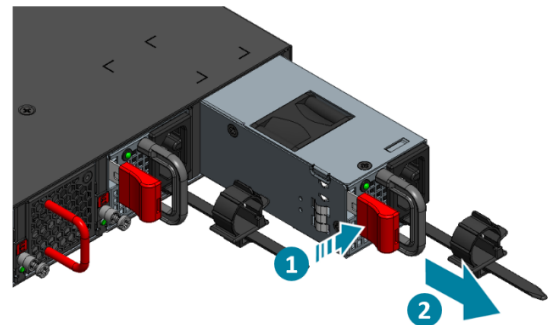

Figure 24.

3. Align the new PSU with the power bay, ensuring the PSU's power connector is in the correct position.
4. Carefully slide the new PSU into the power bay and gently push until it is flush with the case.
5. An audible click will be heard when the PSU is installed correctly. The PSU will not go in all the way if it is in the wrong direction.



Note

Illustrations are for reference purposes only. Actual PSU position may differ.

DC Version:

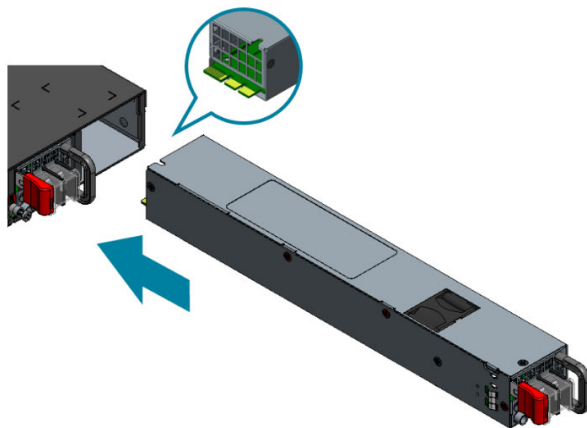

AC Version:

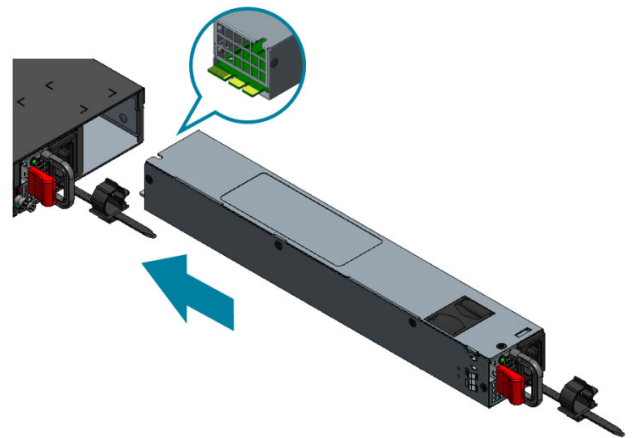

Figure 25.



7 Grounding the Router

It is recommended that equipment changes be done on a grounded rack system. This will reduce or prevent the risk of shock hazards, equipment damage, and potential of data corruption.

The router can be grounded from the router's case, a grounding lug and M4 screws and washers are provided with the package contents, however, the grounding wire is not included. For convenience, there are two locations on the case in which the grounding lug may be fixed.

The following instructions are for grounding the router.



This equipment must be grounded. Do not defeat the ground conductor or operate the equipment without correctly grounding the equipment. If there is any uncertainty about the integrity of the equipment's grounding, please contact the electrical inspection authority or a certified electrician.

1. Before grounding the router, ensure that the rack is properly grounded and in compliance with local regulatory guidelines. Ensure that there is nothing that can obstruct the connection for grounding and remove any paint or materials that may prevent good grounding contact.
2. Strip the insulation from a size #6 AWG grounding wire (not provided within the package contents), leaving 0.5" +/- 0.02" (12.7mm +/- 0.5mm) of exposed grounding wire.
3. Insert the exposed grounding wire all the way into the hole of the grounding lug (provided with package contents).
4. Using a crimping tool, firmly secure the grounding wire to the grounding lug.

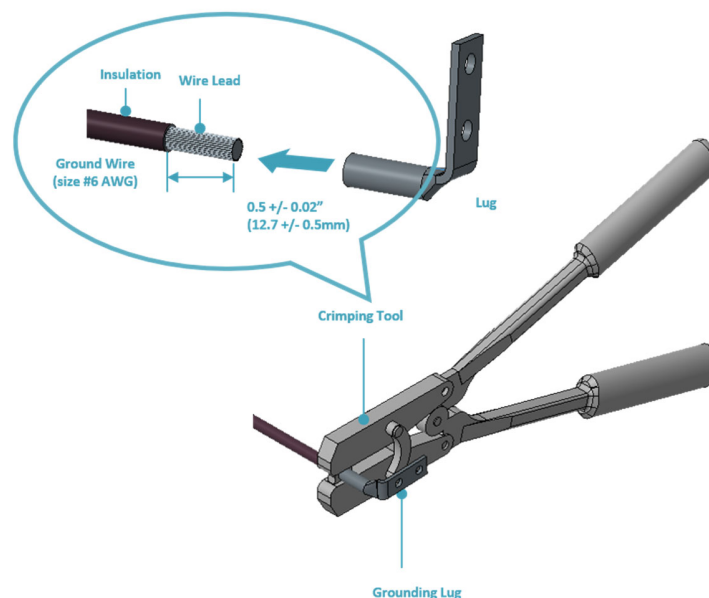

Figure 26.

5. Locate the designated location for securing the grounding lug, which is located on the side of

the router and remove the protective label.

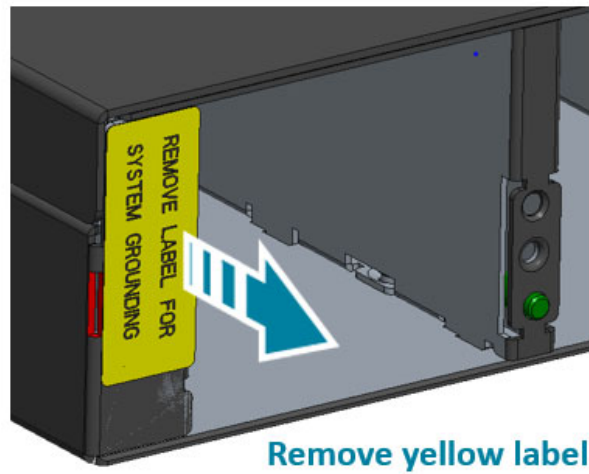

Figure 27.

- Using 2 M4 screws and 2 washers (provided with the package contents), firmly lock the grounding lug to either of the designated grounding locations on the router.

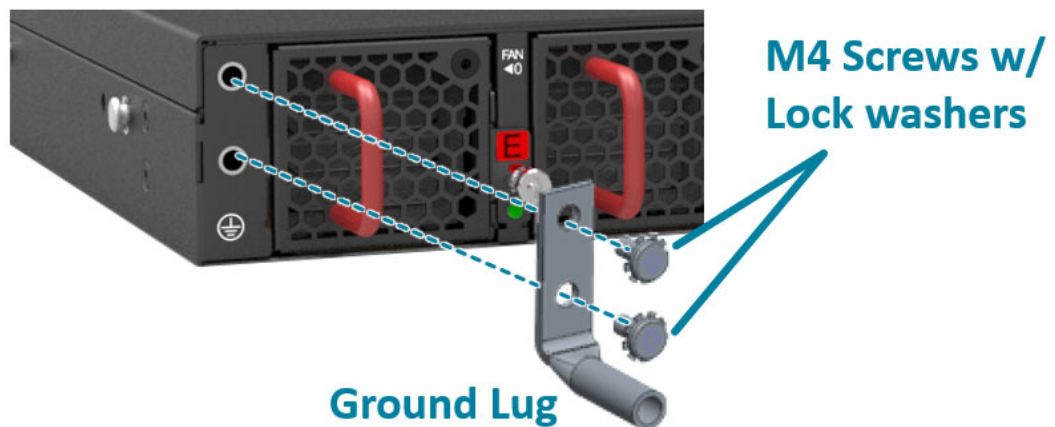

Figure 28.



8 Connecting Power

8.1 DC Version

1. Ensure there is enough power to supply the system.

The maximum system power consumption is 1246 watts. It is recommended to ensure that enough power is reserved from the power distribution system before installation. Also, please ensure that both PSUs have been properly installed before powering up the equipment, as the S9301-32D is designed to support 1 + 1 power redundancy.

2. Attach the DC power cables to the lugs.

The UL 1015, 8 AWG DC power cable (not provided) must be attached to a one-hole lug before connecting to the PSU. The following instructions are for connecting the DC Power Cable to the lug:

2.1 Strip the insulation from a DC Power Cable, leaving 0.5" +/-0.02" (12.7mm +/-0.5mm) of exposed cable

2.2 Insert the exposed DC power cable into the heat shrink tubing, the length of heat shrink tubing should not less than 38.5mm.

2.3 Insert the exposed DC power cable all the way into the hollow tube of the lug (provided with switch package contents).

2.4 Using a crimping tool, firmly secure the DC power cable to the lug. It is recommended to not crimp exceeding the lines indicated on the lug, which is also depicted as the cross-section area in the picture on the below.

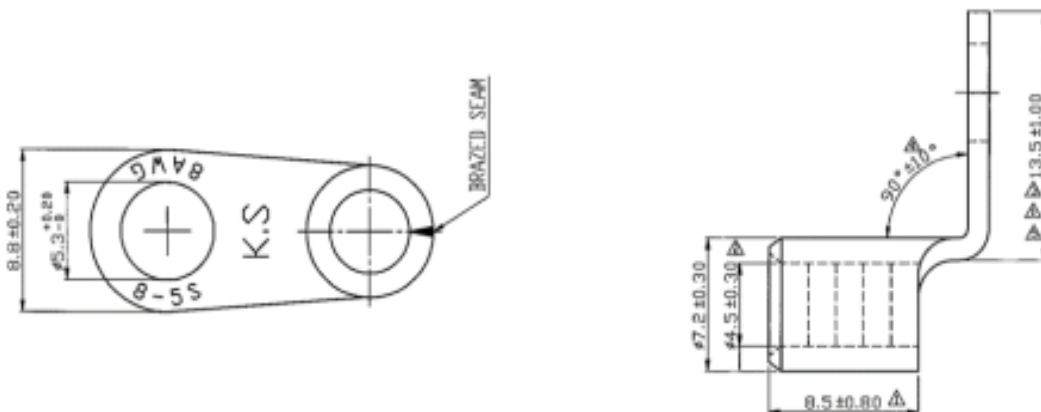

Figure 29.

2.5 Move the heat shrink tubing to cover any exposed metal on the DC power cable and lug.

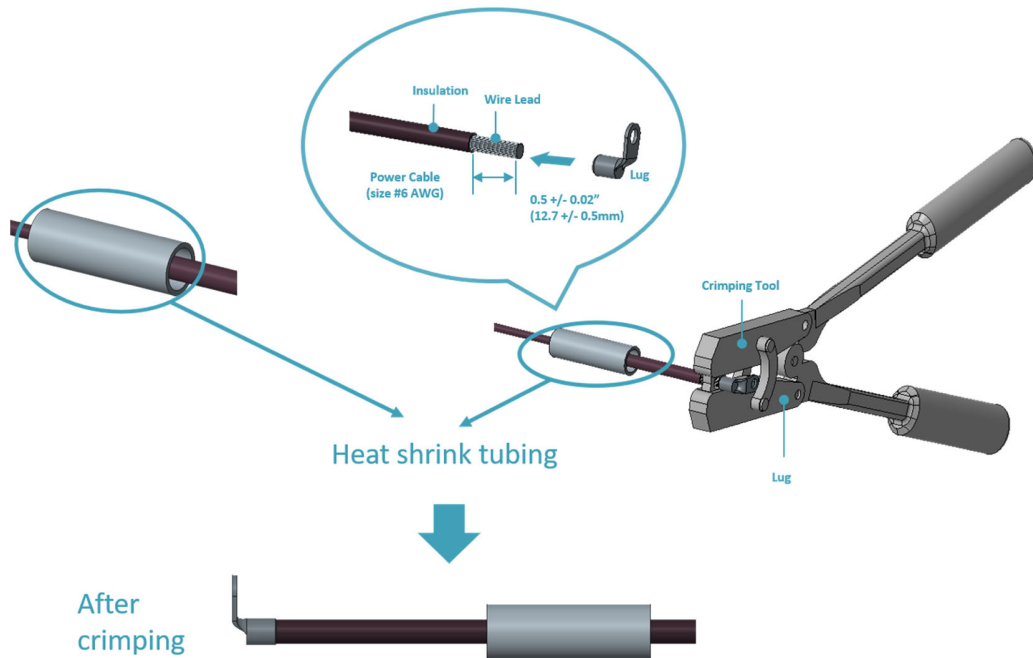

Figure 30.

2.6 Use a heat source to secure the heat shrink tubing in place. Allow the heat shrink tubing to cool before attaching the DC power cable. An example of the installed DC version with insulation material as below.

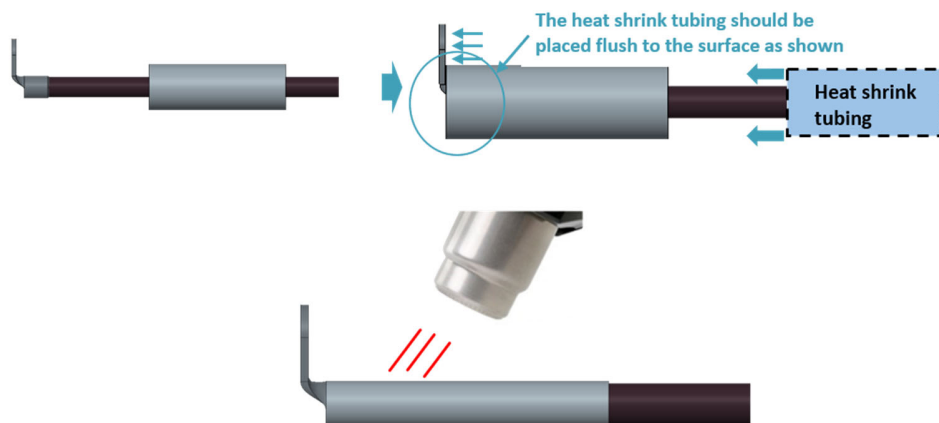

Figure 31.

3. Attach the power cable.

Locate the DC power screw-type terminal block located on the PSU. Remove the plastic cover that is protecting the terminal block by pushing from the top or bottom of the cover and

flipping open the cover outwards. Secure the one-hole lug (with the DC power cable attached) to the terminal block as depicted in the following figure.

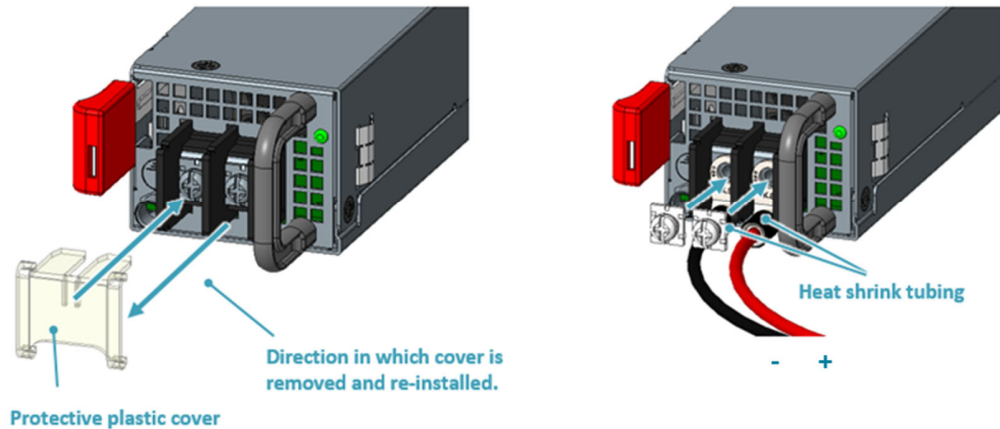

Figure 32.

4. Tighten the screws to the specified torque.
Tighten the screws to a torque value of $14.0 \pm 0.5 \text{ kgf.cm}$. If the torque is not enough, the lug will not be secure and may cause malfunctions. If the torque is too much, the terminal block or lug may be damaged. Secure the plastic cover back onto the terminal block. The figure below depicts how it should look once the lug is attached and the protective plastic cover reinstalled.

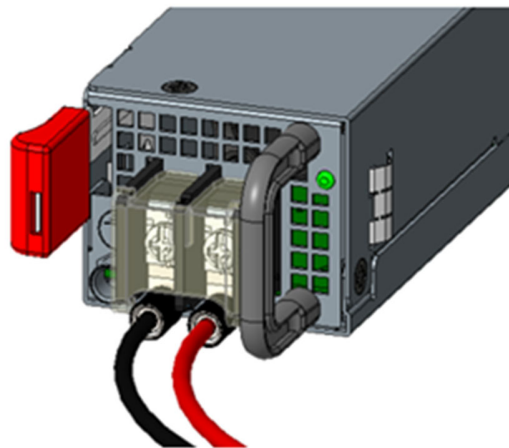

Figure 33.

5. Feed DC power into the system.
The PSU will immediately output 12V and 5VSB to the system with a -40 to -75V DC power source. The PSU has a built in 60A, fast acting fuse based on the PSU maximum capacity, which will act as a second tier system protection in case the power distribution unit's fuse is not functioning.
6. Verify that the power supply is operating.
If connected correctly, when turned on, the LED on the PSU will light up with a Green color designating normal operation.

8.2 AC version

1. Ensure there is enough power to supply the system.
The maximum system power consumption is 1246 watts. It is recommended to ensure that enough power is reserved from the power distribution system before installation. Also, please ensure that both PSUs have been properly installed before powering up the equipment, as the S9301-32D is designed to support 1 + 1 power redundancy.
2. Attach the power cable.
Locate the AC inlet connector on the PSU and plug the AC power cable (250VAC 15A, IEC60320 C15) into the AC inlet connector.
3. Feed AC power into the system.
The PSU will immediately output 12V & 5VSB to the system with a 200 to 240V AC power source. The PSU has a built-in 16 amperes, fast acting fuse based on the PSU maximum capacity, which will act as a second tier system protection in case the power distribution unit's fuse is not functioning.
4. Verify that the power supply is operating.
If connected correctly, when turned on, the LED on the PSU will light up with a solid Green color designating normal operation.



If only a 110V AC power source is available, the S9301-32D can still be powered with both PSUs providing 1000 watts each for a total output of 2000 watts. However, in this case, if one PSU stops functioning, the power output would be inefficient to sustain the router's operation.



9 Verifying System Operation

9.1 Front Panel LED

Verify basic operations by checking the system LEDs located on the front panel. When operating normally, the SYS, FAN, and PSU LEDs should all display green.

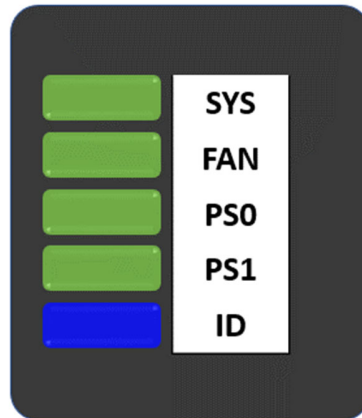

Figure 34.

LED Condition	Equipment Status
SYS	
Off	No power
Solid Green	Host CPU/BMC boot complete
Solid Amber	Power is up but Host CPU/BMC boot failed
FAN	
Off	Fans are not initialized
Solid Green	All Fans are work normal
Blinking Amber	Fan fail: one or more Fans need service
PSU0	
Off	No power
Solid Green	PSU0 working normal
Blinking Amber	PSU0 fail (PSU0 needs service)
PSU1	
Off	No power
Solid Green	PSU1 working normal
Blinking Amber	PSU1 fail (PSU1 needs service)
ID	
Off	No Power
Blinking Blue	Beacon feature is enabled on the switch

9.2 PSU FRU LED

Additional information about PSU status can be obtained by the LEDs located on the PSU itself.

LED Condition	Equipment Status
Off	No input power to all power supplies.
Green	Output ON and OK
Blinking Green	PSU standby state input power present / Only +5VSB on.
Blinking Green	Power supply firmware updating (Boot-loader mode).
Red	Power supply critical event causing a shutdown, failure, over current, short circuit, over voltage, fan failure, and/or over temperature.
Blinking Red	Input power cord unplugged or input power lost with a second power supply in parallel still with AC input power.
Blinking between Green and Red	Power supply warning events where the power supply continues to operate; high temp, high power, high current, and/or slow fan.

9.3 Fan FRU LED

LED Condition	Equipment Status
Off	No input power
Solid Green	Fan is functioning normal
Solid Amber	Fan is abnormal, service is required

9.4 Management Port LED

LED Condition	Equipment Status
Left LED	
Off	No power
Solid Green	1G link-up
Blinking Green	1G TX/RX activity
Right LED	
Off	No power
Solid Amber	10M/100M link-up
Blinking Amber	10M/100M TX/RX activity



10 Initial System Setup

Establishing a first-time serial connection.

To assign an IP address, you must have access to the command line interface (CLI). The CLI is a text-based interface that can be accessed through a direct serial connection to the device.

Access the CLI by connecting to the console port. After you assign an IP address, you can access the system through Telnet or SSH by Putty, TeraTerm or HyperTerminal.

Perform the following steps to access the device through a serial connection:

1. Connect the console cable.
 - The console can be connected using the RJ45 port labelled IOIO.
 - To connect to console, plug a RJ45 serial cable into the console port and connect the other end to the computer. Cable types may vary depending on the model.

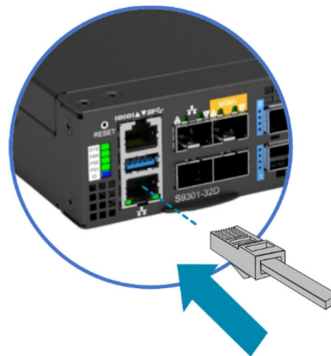

Figure 35.

2. Check for serial control availability.
Disable any serial communication programs running on the computer such as synchronization programs to prevent interference.
3. Launch a terminal emulator.
Open a terminal emulator application such as HyperTerminal (Windows PC), Putty or TeraTerm and configure the application. The following settings are for a Windows environment (other operating systems will vary):
 - Baud rate: 115200 bps
 - Data bits: 8
 - Parity: None
 - Stop bits: 1
 - Flow control: None
4. Login to the device.
After the connection is established, a prompt for the username and password displays. Enter the username and password to access the CLI. The username and password should be provided by the Network Operating System (NOS) vendor.



11 Cable Connections

11.1 Connecting the USB Cable

Connect the USB 3.0 A Type plug (male connector) into the USB port (female connector) located on the front panel of the router.

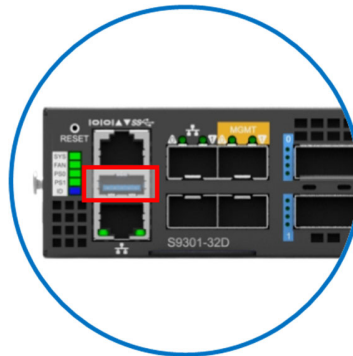

Figure 36.



11.2 Connecting the OOB Management Cables



Note

We recommend that you use a Category 5 (Cat 5e) cable for the OOB management.

There are two types of OOB management ports that can both access the x86 for management purposes.

1. The first port type is the RJ45 OOB port marked a  symbol.
2. The second port type is the two 10G SFP+ ports also marked with a  symbol.

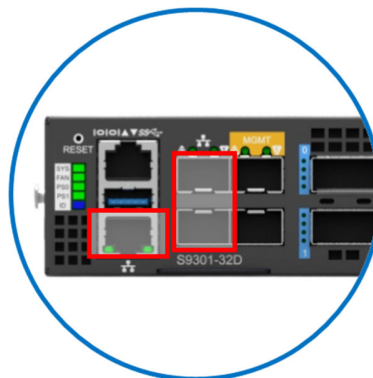

Figure 37.

11.3 Connecting the Management Cables

There are other two 10G SFP+ ports also available for management. These ports are marked with an orange “MGMT”. They can be used as both Ethernet ports or in-band management ports.

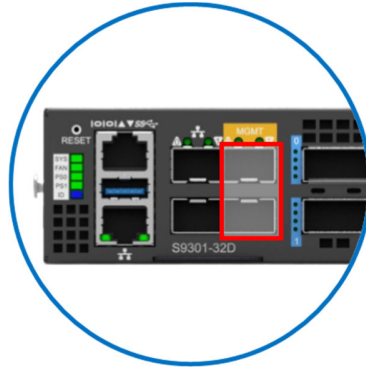

Figure 38.

11.4 Connecting the Transceivers



Note

To prevent over tightening and damaging the optical fibers, it is not recommended to use tie wraps with optical cables.

Read the following guidelines before connecting the transceiver:

- Before installing the router, take into consideration rack space requirements for cable management and plan accordingly.
- It is recommended to use hook-and-loop style straps to secure and organize the cables.
- For easier management, label each fiber-optic cable and record its respective connection.
- Maintain a clear line of sight to the port LEDs by routing the cables away from the LEDs.



Caution

Before connecting anything (cables, transceivers, etc.) to the router, please ensure to discharge any static electricity that may have built up during handling. It is also recommended the cabling be done by a professional who is grounded, such as by wearing an ESD wrist strap.

Please follow the steps below for connecting a transceiver.

1. Remove the new transceiver from its protective packaging.
2. Remove the protective plug from the transceiver port.
3. Place the bail (wire handle) in the unlocked position and align the transceiver with the port.
4. Slide the transceiver into the port and use gentle pressure to secure it in place. An audible click can be heard when the transceiver is secured in the port.



12 Cautions and Regulatory Compliance Statements



Safety Notices

Caution! Shock hazard!

TO DISCONNECT POWER, REMOVE ALL POWER CORDS FROM UNIT.



Electrical Hazard: Only qualified personnel should perform installation procedures.
Risques d'électrocution: Seul un personnel qualifié doit effectuer les procédures d'installation.



Warning: Network Switch power supplies do not have switches for turning the unit on and off. Before servicing, disconnect all power cords to remove power from the device. Make sure that these connections are easily accessible.

Avertissement: Network Switch alimentations ne sont pas des interrupteurs pour allumer l'appareil et en dehors. Avant l'entretien, débranchez tous les cordons d'alimentation pour couper l'alimentation de l'appareil. Assurez-vous que ces connexions sont facilement accessibles.



Caution: Before mounting the device, ensure that the rack can support it without compromising stability. Otherwise, personal injury and/or equipment damage may result.



Caution: Use of controls or adjustments or performance of procedures other than those specified herein may result in hazardous radiation exposure.



Caution: Only Laser Class 1 optical transceivers shall be used.



Warning: Do not use optical instruments to view the laser output. The use of optical instruments to view laser output increases eye hazard. Use only UL/CSA, IEC/EN60825-1/-2 recognized pluggable modules.

Avertissement: Ne pas utiliser d'instruments optiques pour voir la sortie du laser. L'utilisation de instruments optiques pour afficher la sortie laser augmente les risques oculaires. Utilisez uniquement UL/CSA, IEC/EN60825-1 /-2 reconnu modules enfichables.



Warning:

The equipment should only be used within a restricted access area.

The equipment should only be operated by skilled or instructed persons.

The equipment and its modules should only be repaired, maintained or replaced by skilled personnel.

Instructed person is a term applied to persons who have been instructed and trained by a skilled person, or who is supervised by a skilled person.



< 電源コードセットに関する使用上の注意事項 >

付属の「AC電源コードセット」は、本製品専用のものです。他の電気機器には絶対に使用しないでください。

Class A ITE Notice



This equipment is compliant with Class A of CISPR 32. In a residential environment this equipment may cause radio interference.

VCCI Notice

This is Class A equipment. Operation of this equipment in a residential environment could cause radio interference. In such a case, the user may be required to take corrective actions.

この装置は、クラスA機器です。この装置を住宅環境で使用すると電波妨害を引き起こすことがあります。この場合には使用者が適切な対策を講ずるよう要求されることがあります。

VCCI-A

警告使用者：

此為甲類資訊技術設備，於居住環境中使用時，可能會造成射頻擾動，在此種情況下，使用者會被要求採取某些適當的對策。

此为A级产品，在生活环境中，该产品可能会造成无线电干扰。

在这种情况下，可能需要用户对干扰采取切实可行的措施。

The logo for ufiSpace, featuring the word "ufiSpace" in a bold, white, sans-serif font. The "i" in "ufi" has a dot, and the "S" in "Space" is larger and more prominent. The text is centered on a dark red, trapezoidal background that is part of a larger graphic design with geometric shapes and a gradient.

Unifying Cloud & Carrier Networks

www.ufispace.com